

### PRODUCT SHEET

## STAND-UP LIFT **WAY UP'GO ECP**

#### Descriptif :



- Quick electric footrest spreader, in just 3 seconds. Can be use with all types of chairs
- Improved maneuverability and rollability with the central wheel under the patient
- Motorized assistance for effortless movement under load
- Platform cushioning for improved threshold clearance
- Can be folded, split and stored upright
- Steel frame
- Laser-cut and bent sheet metal, tubes and profiles
- Baked epoxy paint
- Total weight ECP version: 40.20 kg
- Ball-bearing wheels
- Weight of upper part: 17.40 kg (with one axis and two wheels)
- Weight of ECP base: 22.80 kg (with another axis and two wheels)
- Maximum weight : 180 kg
- Product life: 8 years\* (excluding electrical part)
- \* Subject to regular maintenance
- Lithium battery: 2-year warranty

- Medical devices (Regulation (EU) 2017/745)
- Compliance with the following standards:
- NF EN 60601-1 : 2006 A1/2013
- NF EN 60601-1-2 : 2015
- NF EN ISO 10535 : 2021
- Electromagnetic compatibility
- 24V low-voltage DC motors
- Power 24 V/120 VA
- Maximum thrust force: 8,000 N
- Electronic overload protection
- Protection class: II
- Type of protection: IP X4
- Contactor limit switches
- ABS housing
- Remote control with coiled cable, low voltage 24V
- Overload protection by thermo-motor switches
- Noise level: 60 dB at 1 m

#### Motor specifications

- Control box with removable high-capacity battery
- Graduated battery charge indication
- Autonomy indicator light
- Mains charger 220V-24V
- Emergency stop button
- 4-function remote control IPX4 protection (up/down, forward/backward))
- Emergency lowering : electric and manual B D
- Mains charger connection for battery charging

#### Dimensional characteristics

- A.** Total length : 1065 mm
- B.** Minimum useful height : 950 mm
- C.** Max. useful height : 1160 mm
- D.** Total height (excluding remote control) : 946 mm
- E.** Frame height : 112 mm
- F.** Minimum base width : 565 mm (Closed)
- G.** Max. baseplate width: 1100 mm
- H.** Turning diameter : 1080 mm
- I.** Ground clearance : 40 mm

**In upright folded storage** (see photo opposite) :

- A.** Width: 550 mm
- B.** Depth : 555 mm
- C.** Height : 1200 mm

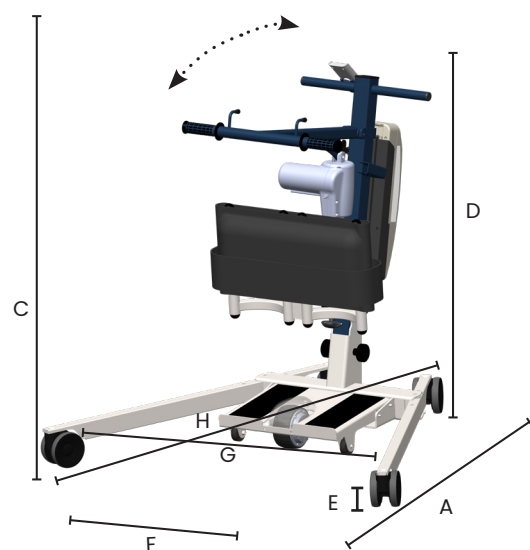
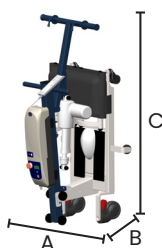

Non-contractual visual

**Packaging :** 1000x600x600 mm (stackable till 3 units)

- Pallet 800x1200 mm : up to 3 units
- Pallet 1000x1200 mm : up to 6 units